

# ENGINEERING THERMODYNAMICS

Dr. Pankaj Kumar  
Dr. Jitendra Katiyar

**KHANNA PUBLISHERS**

*Investing in Learning*



---

# ENGINEERING THERMODYNAMICS

---

Dr. Pankaj Kumar

*Research Assistant Professor*

Dr. Jitender Katiyar

*Research Assistant Professor*



**KHANNA PUBLISHERS®**

*Operational Office : Investing in Learning®*

4575/15, Onkar House, Opp. Happy School,  
Ground Floor, Daryaganj, New Delhi 110 002

*Phones : 011-45033819 • Mob. 09811541460*

*email : contactus@khannapublishers.in*

*Published by :*

Romesh Chander Khanna & Vineet Khanna  
for **KHANNA PUBLISHERS**  
2-B, Nath Market, Nai Sarak  
Delhi- 110 006 (India)

**Website : [www.khannapublishers.in](http://www.khannapublishers.in)**

© 1979 and onward

*This book or part thereof cannot be translated or reproduced in any form without the written permission of the Authors and the Publishers. The right to translation, however, reserved with the author alone.*

**Copyright: Authors and Publishers Jointly**

Hologram & Description

To all readers of our books, from yourself if being defrauded by pirates to prevent, please make sure that there is an Hologram on the cover of our books with the below specifications. If you find any book without Hologram and Description, please mail us at [contactus@khannapublishers.in](mailto:contactus@khannapublishers.in)

Thanking you

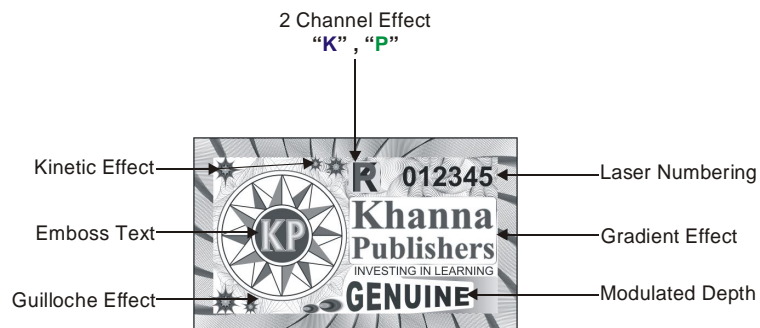

**ISBN No. 978-93-87394-69-8**

***First Edition : 2019***

## ***Preface***

---

This book which deals with ***Engineering Thermodynamics*** is based on the study of the relationship between heat (*thermos*) and work (*dynamics*). It basically deals with energy interactions in physical system where concepts of thermodynamics are used to solve engineering problems like calculating the fuel efficiency of engines and finding ways of making more efficient systems like rockets, refineries, nuclear reactors, etc. Thermodynamics can be stated in four laws called the zeroth, first, second, and third laws respectively.

This book on thermodynamics, written in an unconventional and a 'student-friendly' style, is the outcome of fantastic experience of interaction with different scholars.

We would also like to express our heartfelt gratitude and sincere thanks to the all faculty members of SRM Institute of Science and Technology, Kattankulathur for their encouraging feedbacks on the subject. At a more personal level, we acknowledge a deep debt to our teachers, collaborators, students and our family members who have supported us over the years.

Last but not the least, we also thank our publisher who has taken much pain to publish this book and bring it to the broad daylight. Every care has been taken to eliminate errors but we always look forward and shall appreciate criticisms and suggestions towards the improvement of the book.

—Authors

# Contents

---

<b>1. Pressure and Its Measurement</b>	<b>1—12</b>
1.1. Introduction	1
1.2. Atmospheric Pressure and Temperature	2
1.3. Pressure Measurement Devices	4
1.3.1. Barometer	4
1.3.2. Bourdon Tube Pressure Gauge	4
1.3.3. U-tube Manometer	5
<b>2. Temperature and Its Measurement</b>	<b>13—20</b>
2.1. Introduction of Temperature	13
2.2. Zeroth Law of Thermodynamics	13
2.3. Mercury Thermometer	14
2.4. Celsius Scale	14
2.5. Fahrenheit Scale	14
2.6. Absolute Scale	14
2.7. Gas Thermometer	14
2.7.1. Constant Volume Gas Thermometer	15
2.7.2. Constant Pressure Gas Thermometer	15
2.8. Thermocouple Thermometers	15
2.9. Resistance Thermometer	15
2.10. Ideal Gas Temperature	16
<b>3. Introduction and Basic Concept</b>	<b>21—29</b>
3.1. Introduction of Thermodynamics	21
3.2. Macroscopic and Microscopic Approach	22
3.3.1. Thermodynamic System	23
3.3.2. Boundary	23
3.3.3. Surrounding	23
3.3.4. Universe	23
3.4. Classification of Thermodynamic System	23
3.4.1. Closed System (Control Mass System)	23
3.4.2. Open System (Control Volume System)	23
3.4.3. Isolated System	24
3.5. Thermodynamic Equilibrium	24
3.6. Thermodynamic Properties	24
3.6.1. State of System	25
3.6.2. Path of System	25
3.6.3. Process of System	25
3.6.4. Cycle of System	25
3.7. Phase of a Substance	25
3.8. Quasi-Static Process	26
3.9. Pure Substance	26
3.10. Concept of Continuum	27

<b>4. Transient Energy : Work and Heat</b>	<b>30—59</b>
4.1. Work Transfer	30
4.1.1. Displacement Work	31
4.1.2. Paddle Work	31
4.1.3. Flow Work	32
4.1.4. Displacement Work for various Quasi-static Processes	32
4.2. Point Function and Path Function	34
4.2.1. Point Function	34
4.2.2. Path Function	35
4.3. Reversible and Irreversible Process	38
4.3.1. Reversible Process	38
4.3.2. Irreversible Process	39
4.4. Free Expansion	39
4.5. Indicator Diagram	40
4.6. Heat Transfer	42
4.7. Mode of Heat Transfer	42
4.7.1. Conduction	42
4.7.2. Convection	43
4.7.3. Radiation	44
4.8. Combine Mode of Heat Transfer	45
4.9. Specific Heat and Latent Heat	46
4.10. Comparison of Heat and Work	46
4.10.1 Similarities	46
4.10.2. Dissimilarities	46
4.11. Sign Convention	46
<b>5. The First Law of Thermodynamics</b>	<b>60—80</b>
5.1. Law of Conservation of Energy	60
5.2. Joule's Experiment	60
5.3. First Law for a Closed System	61
5.4. The First Law for a Closed System for Process	61
5.5. Application of First Law of Thermodynamic for Closed System.	62
5.6. Internal Energy	62
5.7. Characteristic Gas Constant and Universal Gas Constant	63
5.8. Specific Heat	64
5.8.1. Specific Heat at Constant Volume	64
5.8.2. Specific Heat at Constant Pressure	64
5.9. Enthalpy a Property of System	64
5.10. Joule's law	64
5.11. Isolated System	65
5.12. Perpetual Motion Machine of First Kind PMM1	65
<b>6. Steady Flow Process</b>	<b>81—99</b>
6.1. Steady Flow Process	81
6.2. Mass Balance in a Steady Flow System	81
6.3. Energy Balance in Steady Flow Process i.e., Steady Flow Energy Equation (SFEE)	81
6.4. Application of SFEE for Various Open System	82

# Chap\_1

## *Pressure and Its Measurement*

---

### 1.1. INTRODUCTION

Pressure is defined as the normal component of force per unit area exerted by a fluid (liquid or gas molecules) on a boundary. The pressure is defined only for an area sufficiently large so that fluid may be treated as a continuum. Thus

$$P = \lim_{\Delta A \rightarrow \Delta A'} \frac{\Delta F}{\Delta A}$$

Where  $A'$  is the minimum area for which the fluid behaves as the continuum. The pressure  $P$  of a point in a fluid in equilibrium is same in all direction *i.e.*  $P_x = P_y = P_z$  for static fluid. The thermodynamic pressure is related with the hydraulic pressure which is measured by Bernoulli equation. The thermodynamic pressure is same as hydrodynamic pressure for most of the cases specially for incompressible flows.

In the US engineering system of unit, pressure is expressed in pound per square inch ( $1\text{b/in}^2$  or psia). Also pressure is frequently expressed in term of height of a column of mercury (Hg). The S.I unit for pressure is the newton per square meter or pascal (Pa)

$$1 \text{ Pa} = 1\text{N/m}^2$$

The other unit not within the S.I system is also widely used, bar, more than Pascal unit.

$$1 \text{ bar} = 10^5 \text{ pa} = 100 \text{ kPa}$$

The pressure exerted on a wall by atmosphere is called atmospheric pressure and varies with location and elevation on earth's surface. It is measured by Barometer.

The atmospheric pressure is the weighting air at the particular location. It is measured with help of barometer.

$$1 \text{ atm} = 101.325 \text{ kpa} = 760 \text{ mm of Hg}$$

The pressure measured with respect to atmospheric pressure and absolute zero. Sometime pressure is measured as total pressure which is sum of static pressure and dynamic pressure. From the dalton law of partial pressure, total pressure refers to sum of pressure exerted by individual gas is called absolute pressure. Gauge pressure is difference between absolute and atmospheric pressure and measured above atmospheric pressure as in (Fig. 1.1). Vacuum pressure is the pressure below atmospheric pressure. The term vacuum is synonymous with negative gauge pressure. A perfect vacuum is a place where absolute pressure is zero.

## 2 THERMODYNAMICS

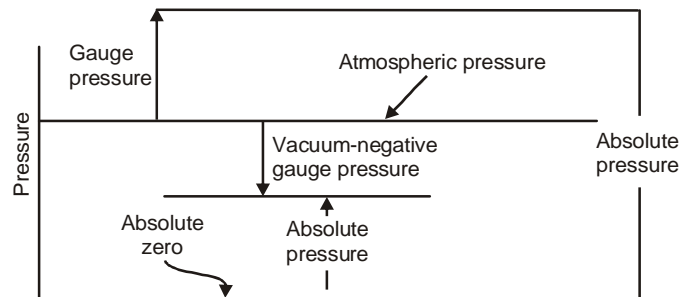

Fig 1.1. Schematic diagram for pressure relation

### 1.2. ATMOSPHERIC PRESSURE AND TEMPERATURE

Standare Temperature and Pressure (STP)-Under standard temperature and pressure, the temperature is taken as 15°C and pressure is taken as 101.32 kpa or 760 mm of Hg.

Normal temperature and pressure (NTP)-Under normal temperature and pressure condition temperature is taken on 0°C and pressure is taken on 101.32 kPa.

**Example 1.1 :** A force of 8000N is applied uniformly on a piston of 8cm diameter at equilibrium. Determine the pressure on the piston.

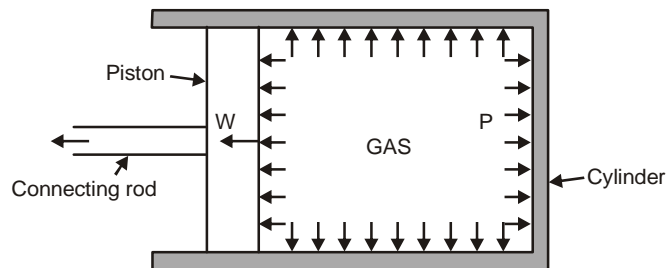

Fig. 1.2. Cylinder-piston arrangement

**Solution:**

Given, force applied = 8000 N.

Diameter of Piston = 8 cm =  $8 \times 10^{-2}$  m

Area of piston =  $\frac{\pi}{4} d^2 = 50.2 \times 10^{-4} \text{ m}^2$

At equilibrium,  $I_{\text{internal}} = E_{\text{external}}$   
 $P \times A = F$

$$P = \frac{F}{A} = \frac{8000}{50.2 \times 10^{-4}} = 1595 \text{ kN/m}^2 \quad (\text{Ans})$$

**Example 1.2 :** An oil of specific gravity 0.6 is contained in a column of height 160 cm. Determine the pressure in kN/m<sup>2</sup>.

**Solution:**

Given, specific quantity = 0.6

Height of column = 160 cm =  $160 \times 10^{-2}$  m

Specific Gravity =  $\frac{\text{density of liquid}}{\text{density of water}}$



## 4 THERMODYNAMICS

$$300 \text{ torr} = 300 \text{ mm of Hg}$$

$$P_{gauge} = \rho gh = 0.3 \times 9.8 \times 13600 = 40.03 \text{ kPa}$$

$$P_{absolute} = P_{atm} + P_{gauge} = 101.32 + 40.03 = 141.35 \text{ kPa} \quad (\text{Ans})$$

### 1.3. PRESSURE MEASUREMENT DEVICES

The instruments that we generally use either mechanical, electro-mechanical or electronic, are recording pressure as the difference between two pressure i.e. pressure exerted by fluid and ambient atmospheric pressure.

**Mechanical instruments :** These instruments in which pressure measurement is made by balancing of two forces, one is known and other is unknown. The deflection due to force is measured and suitably converted to pressure output. examples like Bourden Gauge, diaphragm gauge, bellows gauge.

**Electro mechanical instruments :** Here the pressure is first felt by mechanical forces and then converted to signal by suitable electric components. Example-bridgeman pressure sensor.

**Electronic instruments :** Depend on physical change occurs in which can be detected and recorded electronically.

#### 1.3.1. Barometer

It is scientific device to use for measurement of atmospheric pressure. It can measure the pressure exerted by the atmosphere by using water, air or mercury. Design changes to make it more sensitive, simpler to read and easier to transport. Consider a glass tube sealed at top and this inverted tube is inserted in to a container with liquid filled. As there is no pressure inside the tube so only atmospheric pressure acts over the liquid surface and the liquid will forced up the tube and it will until the height of liquid above the surface level is sufficient to create a pressure of this level to atmospheric pressure.

The pressure in liquid column =  $P = \rho gh$   
where  $g$  = gravitational constant  
 $h$  = height of liquid in column = 10.32 m in case of water  
= 760 mm in case of mercury.  
 $P$  = Atmospheric pressure =  $1.013 \times 10^5 \text{ Pa}$

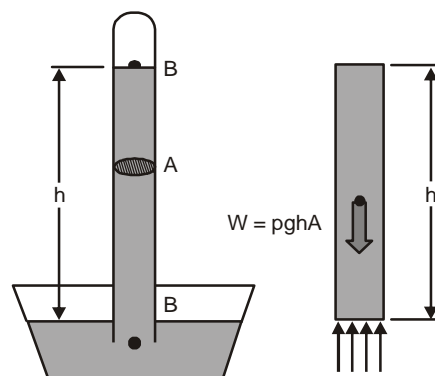

Fig. 1.3. Barometer.

#### 1.3.2. Bourdon tube pressure Gauge

A Bourdon tube pressure Gauge is created to measure up to high pressure of 1.2 bar which cannot measure with manometer. This measures the difference between the system pressure

and atmospheric pressure and it measures gauge pressure as well as vacuum pressure.

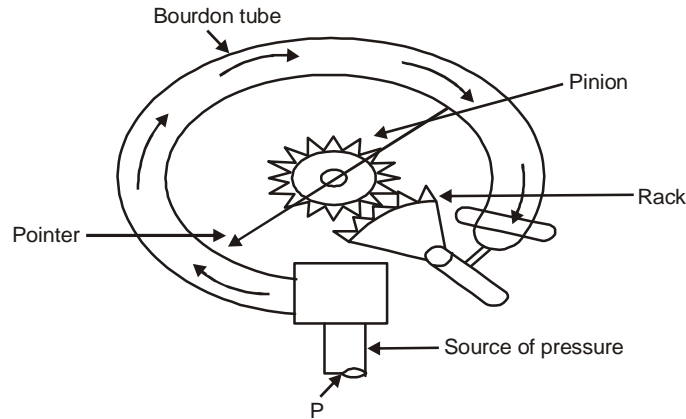

Fig. 1.4. Bourdon tube

The elements of this pressure gauge are shown in (Fig. 1.4). The basic element tube A which is in elliptical shape. The end B of this tube is sealed and connected to rack and pinion arrangement. The tubes are generally made of bronze or nickel steel. When one end of tube is connected to the source of pressure, the internal pressure causes the tube to expand so hoop stress is setup. The force end of tube moves and is in turn connected by suitable levers to a rack which engage with a small pinion mounted on the some spindle on pointer. The pressure is indicated by pointer over on dial which is graduated in a suitable scale.

**Advantage -**

1. Easy to manufacture and less costly.
2. Wide range of availability.
3. Excellent sensitivity.
4. Capable to measure gauge, absolute and differential pressure.

**Disadvantage**

1. Insuitable for low pressure range.
2. Susceptibility to shock and vibration.

**1.3.3. U-tube Manometer**

The manometer is used for measuring the pressure difference between two systems. When there is no pressure applied the height of liquid in both legs is same. When one end of U-tube is connected to the point where pressure is to be measured and other end of tube is either exposed to atmosphere or closed. Due to rise or fall of liquid level the pressure difference is calculated. where

- $P_1$  = Pressure in continer
- $\rho_1$  = density of liquid in container
- $h_1$  = height of liquid in container.
- $\rho_2$  = density of liquid in column
- $h_2$  = height of liquid in column

For U-tube manometer-

$$P_1 + \rho_1 gh_1 = \rho_2 gh_2 + P_{atm}$$

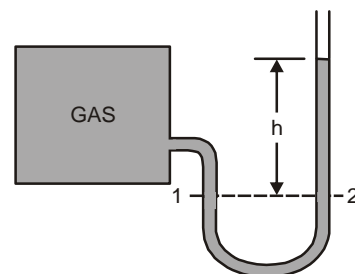

Fig. 1.5. U tube-manometer

## 6 THERMODYNAMICS

For gas filled

$$\rho_1 g h_1 \ll \text{so neglected}$$

### Gauge Pressure Calculation

For liquid filled case (Fig. 1.6)

$$P + \rho_L g h = \rho_{Hg} g Z + P_{atm}$$

For gas filled case (Fig. 1.7)

$$P = \rho_{Hg} g Z + P_{atm}$$

### Vacuum Pressure Calculation

For liquid filled case (Fig. 1.8)

$$P + \rho_L g h + \rho_{Hg} g h = P_{atm}$$

For gas filled case (Fig. 1.9)

$$P + \rho_{Hg} g Z = P_{atm}$$

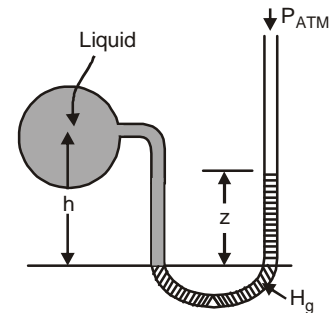

Fig. 1.6. Gauge pressure.

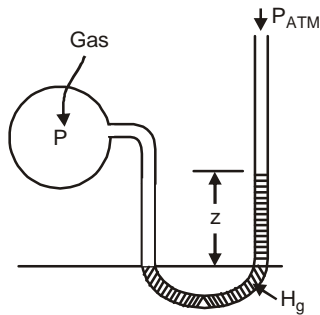

Fig. 1.7. Gauge Pressure

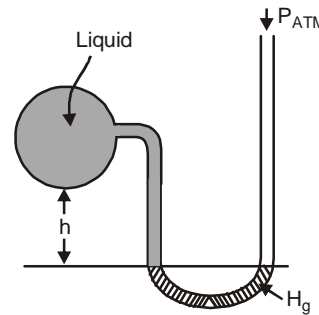

Fig. 1.8. Vacuum Pressure

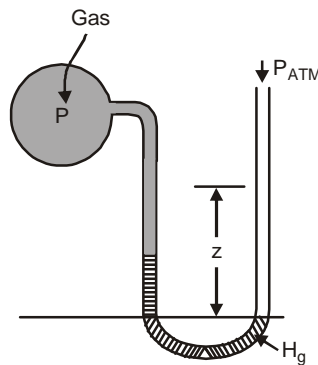

Fig. 1.9. Vacuum Pressure

**Example 1.6 :** A 30 m high vertical column of a fluid of density  $1800 \text{ kg/m}^3$  exists in a place where  $g = 9.8 \text{ m/sec}^2$ . What is the pressure at the base of the column?

**Solution :**

Given density	= 1800
Height ( $h$ )	= 30 m
Gravitational constant	$g = 9.8$
Pressure	= $\rho g h$
	= $1800 \times 9.8 \times 30 = 529020 \text{ Pa}$

**(Ans)**

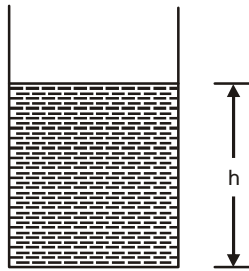

Fig. 1.10. Tube

**Example 1.7 :** A glass tube whose upper end is open contains 50 cm of Hg; 30 cm of water and 40 cm of oil. Determine the gauge pressure

(a) At the base

(b) At the water oil interface and mercury water interface.

(Density of oil is 800 Kg/m<sup>3</sup>)

**Solutions :**

$$\begin{aligned} \text{Gauge pressure at the bottom} &= P_{Hg} + P_{water} + P_{oil} \\ &= \rho_1 g h_1 + \rho_2 g h_2 + \rho_3 g h_3 \\ &= 13600 \times 9.8 \times 50 \times 10^2 \\ &= 800 \times 9.8 \times 40 \times 10^2 \\ &= (66640 + 2940 + 3136) \\ &= 72.716 \text{ kPa} \end{aligned}$$

$$\begin{aligned} \text{Gauge pressure at water mercury interface} &= P_{oil} + P_{water} \\ &= 2940 + 3136 = 6.076 \text{ kpa} \end{aligned}$$

$$\begin{aligned} \text{Gauge pressure at water oil interface} &= P_{oil} \\ &= 3.136 \text{ kPa} \end{aligned}$$

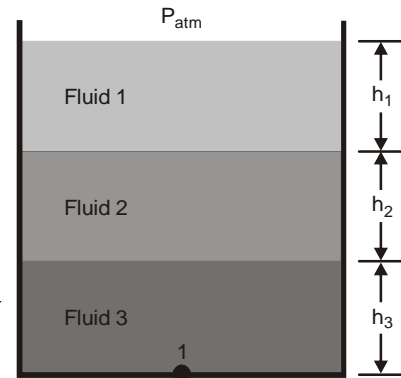

Fig. 1.11. Tube

**Note :** For absolute pressure we have to add  $P_{atm}$ .

**(Ans)**

**Example 1.8 :** In a pipe line the pressure of gas is measured with mercury manometer having one limb open to atmosphere. If the difference in the height of mercury in two limbs is 500 mm, calculate the gas Pressure?

**Solution:**

Equating the pressure at a some reference level i.e.,  $P_a = P_b$

$$\text{Pressure at left arm} = P_a = p$$

$$\text{Pressure at right Arm} = P_b = PHg + P_0$$

Therefore,

$$\begin{aligned} P &= PHg + P_0 \\ &= pgh_1 + pgh_2 \\ &= 13600 \times 9.8 \times 0.760 + 13600 \times 9.8 \times 0.5 \\ &= 167.93 \text{ kPa} \end{aligned}$$

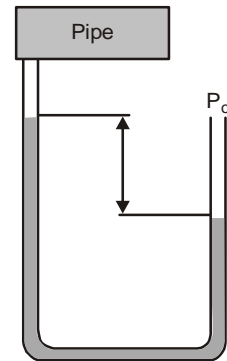

Fig. 1.12. Tube

**(Ans)**

**Example 1.9 :** A gas flows in a pipe fitted with a u-tube manometer. The level of the liquid in the manometer arm open to the atmosphere is 170 mm lower than the level of liquid in the

## 8 THERMODYNAMICS

arm connected to tem pipe. The density of liquid is  $800 \text{ kg/m}^3$ . Find the absolute pressure of the gas if the manometer reads 760 mm of Hg.

**Solution :** Equating the pressure on both Arm of a same reference level.

$$\begin{aligned}
 P_A &= P_B \\
 P_{gas} + P_{liq} &= P_{atm} \\
 P_{gas} + \rho_1 g h_1 &= \rho_2 g h_2 \\
 P_{gas} &= (13600 \times 9.8 \times 0.760) - (800 \times 9.8 \times 0.170) \\
 &= 100.01 \text{ kPa}
 \end{aligned}$$

(Ans)

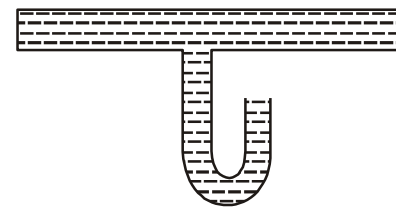

Fig. 1.13. U-tube pipe

**Example 1.10 :** A manometer using Hg ( $\rho = 13600 \text{ kg/m}^3$ ) as the manometric fluid gives a reading of  $z \text{ cm}$  when attached to a vessel containing a liquid of specific gravity 0.8

**Solution :**

Density of liquid =  $8 \times 1000 = 800 \text{ kg/m}^3$

Equating the pressure on both arm at same level

Pressure at left arm =  $P + \rho_1 g h_1$

Pressure at Right arm =  $P_{atm} + \rho_{hg} g h_{hg}$

Therefore, equating both  $P = P_{atm} + \rho_{hg} g h_{hg} - \rho_1 g h_1$

$$\begin{aligned}
 &= 101325 + (13600 \times 9.8 \times 2 \times 0.12) - (800 \times 9.8 \times 5 \times 0.12) \\
 &= 104.382 \text{ kPa}
 \end{aligned}$$

(Ans)

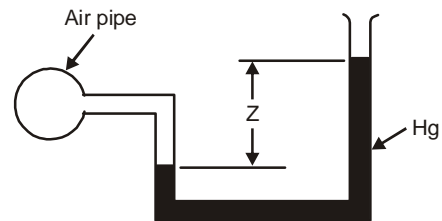

Fig. 1.14. U-tube tank

**Example 1.11 :** In a given figure determine the pressure of water tank?

**Solution :** We must go with a balancing of pressure by symmetry

So required equation will be

$$P + \rho_W g h_1 + \rho_{oil} g h_2 = \rho_{Hg} g h_3 + P_{atm}$$

So  $P = \rho_{Hg} g h_3 + P_{atm} + \rho_W g h_1 + \rho_{oil} g h_2$

(Ans)

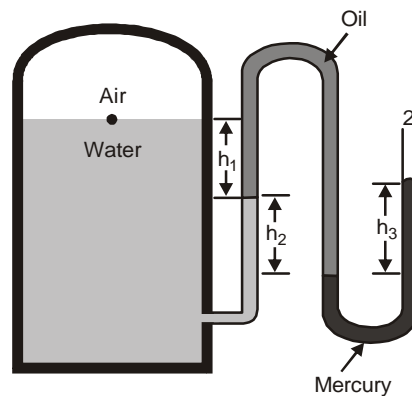

Fig. 1.15. U-tube Manometer

**Note :** The pressure at same horizontal level is always same. This is Principle of Symetry

**Example 1.12 :** In double u-tube manometer find the difference in pressure for oil-1 and oil-2.

**Solution:** By balancing of both side  
We get the required equation-

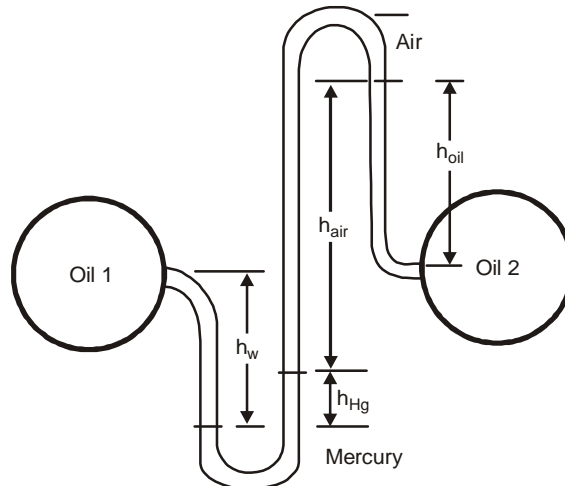

Fig. 1.16. Double Column Manometer.

$$P_{oil1} + \rho_{oil}gh_{oil} + \rho_{oil2}gh_{oil2} = P_{oil2} + \rho_{Hg}gh_{Hg}$$

$$P_{oil1} - P_{oil2} = \rho_{Hg}gh_{Hg} - \rho_{oil}gh_{oil} - \rho_{oil2}gh_{oil2}$$

(Ans)

We neglect the pressure by air due to very less magnitude.

**Key Concept**

- Pressure =  $P = \text{force/area}$
- Specific volume  $v = \text{volume/mass}$
- Density =  $\rho = \text{mass/volume}$
- Specific gravity of liquid [s] = density of liquid/density of water
- Specific gravity of gas[s] = density of gas/density of air
- Assuming in general case
- Density of water =  $1000 \text{ kg/m}^3$
- Density of mercury =  $13600 \text{ kg/m}^3$
- Density of air =  $1.181 \text{ Kg/m}^3$
- Atmospheric pressure =  $101.325 \text{ kPa}$

$$P_{absolute} = P_{atm} + P_{gauge}$$

$$P_{absolute} = P_{atm} - P_{vaccum}$$

**Problem Solving Technique**

- Problem statement
- Schematic
- Assumption and approximation
- Calculation
- Verification

## 10 THERMODYNAMICS

In this chapter it is better to get gauge or vacuum pressure ( $\rho gh$ ). then get absolute pressure.

In case of manometer equate the both side pressure at base level.

**Example 1.13 :** A turbine is supplied with steam at a gauge pressure of 1.5 MPa. After expansion in the turbine the steam flows into a condenser which is maintained at a vacuum of 720 mm of Hg. The barometer pressure is 760 mm of Hg. Express the inlet and exhaust steam pressures in pascal. (Absolute)

**Solution :**

The atmospheric pressure

$$P_o = \rho gh = 13600 \times 9.8 \times 760 \times 10^{-3} = 0.10^3 \text{ MPa}$$

$$\text{Inlet steam pressure} = [1.5 \text{ MPa} + 0.10^3 \text{ MPa}] = 1.603 \text{ MPa}$$

$$\text{Condenser pressure} = (760 - 720) = 40 \times 9.8 \times 10^3 \times 3600 = 5.33 \text{ kPa} \quad (\text{Ans})$$

**Example 1.14 :** The acceleration of gravity is given a function of elevation above sea level by

$$g = 9.806 - 3.086 \times 10^{-9} H$$

Where  $g$  is in  $\text{m/sec}^2$  and  $H$  is in meters. If an airplane weighs 100 kN at sea level, what is the gravity force upon it at 10 km elevation?

**Solution :** Since  $F = W = ma$

Suppose  $w_1, g_1$  are weight and gravity at sea level and  $w_2, g_2$  are weight and gravity at height

$$w_1/w_2 = g_1/g_2$$

$$\text{or} \quad 100/w = 9.806/(9.806 - (3.086 \times 10^{-9} \times 10 \times 10^3))$$

$$100/w = 9,8060/9.8059$$

$$w = 99.99 \text{ kN} \quad (\text{Ans})$$

**Example 1.15 :** The pressure of steam following in a steam pipeline is measured with Hg manometer shown in Fig. Some steam condenses in to water; Estimate the steam pressure is in kPa. Barometer reading is 76 cm of Hg.

**Solution :**

$$\text{Pressure left arm} = P + P_{H_2O}$$

$$P_a = P + \rho_{H_2O} gh_{H_2O}$$

$$\text{Pressure on right arm} = P_{atm} + P_{gh}$$

$$P_b = P_{atm} + \rho_{hg} g \cdot h_{Hg}$$

At same reference level

$$P_A = P_B$$

$$P + \rho_{H_2O} gh_{H_2O} = P_{atm} + \rho_{hg} g \cdot h_{Hg}$$

$$P = P_{atm} + \rho_{hg} g \cdot h_{Hg} - \rho_{H_2O} gh_{H_2O} \quad (\text{Ans})$$

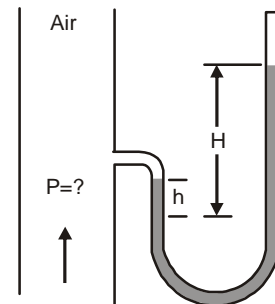

Fig. 1.17. Single column Manometer

**Example 1.16 :** Calculate the pressure exerted by 1 ft column of mercury?

**Solution :** Given height = 1 ft

# ENGINEERING THERMODYNAMICS

## Contents:

1. Pressure and Its Measurement
2. Temperature and Its Measurement
3. Introduction and Basic Concept
4. Transient Energy: Work & Heat
5. The First Law of Thermodynamics
6. Steady Flow Process
7. Second Law of Thermodynamics
8. Pure Substance
9. Entropy
10. Vapor Power Cycle
11. Gases & Their Power Cycle
12. Applications of Thermodynamics
13. Psychrometry
14. Fuel and Combustion
15. Steam Table
16. Formula List



**KHANNA PUBLISHERS®**

ISO 9001:2015

4575/15, Onkar House, Opp. Happy School,  
Ground Floor, Daryaganj, New Delhi-110002

Phones: 011-45033819, 9811541460

E-mail: [contactus@khannapublishers.in](mailto:contactus@khannapublishers.in)



Website:  
[www.khannapublishers.in](http://www.khannapublishers.in)



9 789387 139469 8